

Structural Connections
Reinforcing Bar Couplers

Leviat[®]
A CRH COMPANY

Moment JT Coupler

For rebar connection



International Edition

Imagine. Model. Make.

Leviat®

A CRH COMPANY

We imagine, model and make engineered products and innovative construction solutions that help turn architectural visions into reality and enable our construction partners to build better, safer, stronger and faster.

Leviat is a world leader in connecting, fixing, lifting and anchoring technology.

From the build of new schools, hospitals, homes and infrastructure, to the repair and maintenance of heritage structures, our engineering skills are making a difference around the world.

We provide technical design assistance at every stage of a project, from initial planning to installation and beyond.

Our technical support services range from simple product selection through to the development of a fully customised project-specific design solution.

Every promise we make locally, has the commitment and dedication of our global team behind it. We employ almost 3,000 people at 60 locations across North America, Europe and Asia-Pacific, providing an agile and responsive service worldwide.

Leviat, a CRH company, is part of the world's leading building materials business.



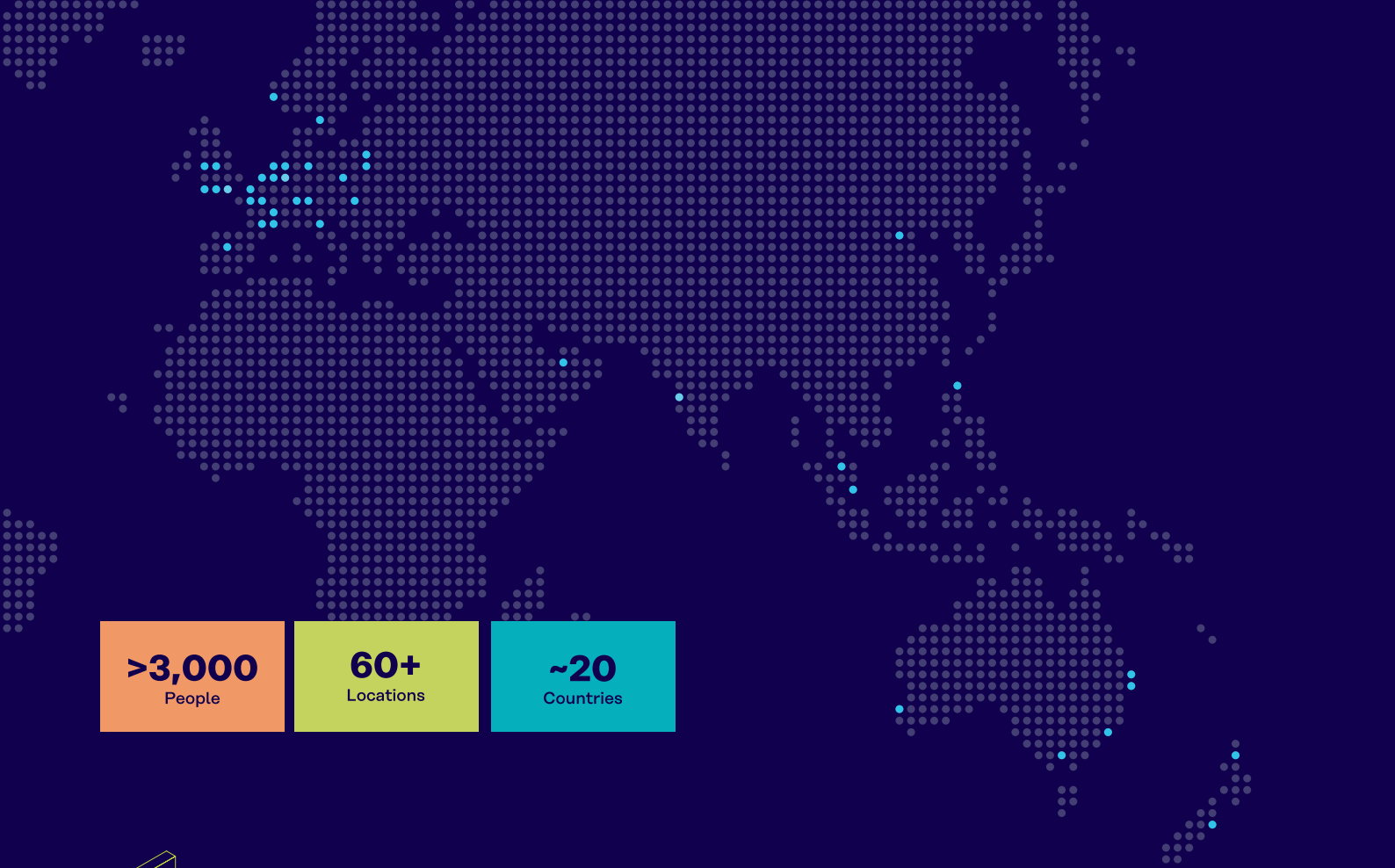

>3,000
People

60+
Locations

~20
Countries

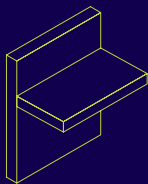

Structural Connections

Systems to form robust, efficient connections, and continuity of concrete reinforcement as necessary, between walls, slabs, columns, beams and balconies, providing structural integrity as well as enhanced thermal and acoustic performance.

- Insulated Balcony Connectors
- Reinforcing Bar Couplers
- Concrete Connections
- Reinforcement Continuity Systems
- Punching Shear Reinforcement
- Shear Load Connectors
- Floor Joint Systems
- Precast / Reinforced Columns
- Infrastructure Products
- Precast Connections
- Acoustic Dowels and Bearings
- Prestress

Other areas of expertise:

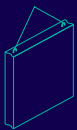

Lifting & Bracing

Systems for the safe and efficient transportation, lifting and temporary bracing of cast concrete elements and tilt-up panels before permanent structural connections are made.



Façade Support & Restraint

Systems for the safe and thermally-efficient fixing of the external building envelope, including brick and natural stone, insulated sandwich panels, curtain walling and suspended concrete façades, and also the repair and strengthening of existing masonry installations.

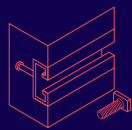

Anchoring & Fixing

Systems for fixing secondary fixtures to concrete, including anchor channels, bolts and inserts; also tension rod systems for roofs and canopies.



Formwork & Site Accessories

Non-structural accessories that complement our engineered solutions and help keep your construction environment operating safely and efficiently, including moulds for casting standard and special concrete elements and construction essentials such as reinforcing bar spacers.

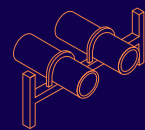

Industrial Technology

Mounting channels, pipe clamps and other versatile framing systems that provide safe fixing in a wide range of industrial applications.

Leviat product ranges:

Ancon | Aschwanden | Connolly | Halfen | Helifix | Isedio | Meadow Burke | Modersohn | Moment | Plaka | Scaldex | Thermomass

Moment JT Couplers

Introduction

Lapped joints are not always an appropriate means of connecting reinforcing bars. The use of laps can be time consuming in terms of design and installation and can lead to greater congestion within the concrete because of the increased amount of rebar used.

Moment JT Couplers can simplify the design and construction of reinforced concrete and reduce the amount of reinforcement required as well as reduction of carbon footprint up to approximately 84% - 90%.

Lapped joints are dependent upon the concrete for load transfer. For this reason any degradation in the integrity of the concrete could significantly affect the performance of the joint. The strength of a mechanical splice is independent of the concrete in which it is located and will retain its strength despite loss of cover as a result of impact damage or seismic event.

Testing and Approvals

Moment JT Couplers are designed and manufactured in accordance with ISO 9001 and comply in all respects to BS8110 and EN 1992-1-1:2004 (Eurocode 2), when used with grade B500B reinforcing bar.

The Moment JT Coupler is designed to exceed the tensile strength of reinforcing bar, up to an equivalent breaking stress of 700MPa in the bar. The standard range of Moment JT Couplers for sizes 16 to 40mm, has been tested and approved by UK CARES to show compliance with the requirements of EN 1992-1-1:2004 (Eurocode 2), BS8110 and UK CARES TA1-F.

The Moment JRT variant of the system has been tested for basic tensile, slip, and elongation performance in accordance with ISO15835 with grade ASTM A615 Grade 60 reinforcement. Tensile, slip, and permanent elongations tests have also been conducted for the Moment JTH high performance coupler with B600 grade reinforcing bar.

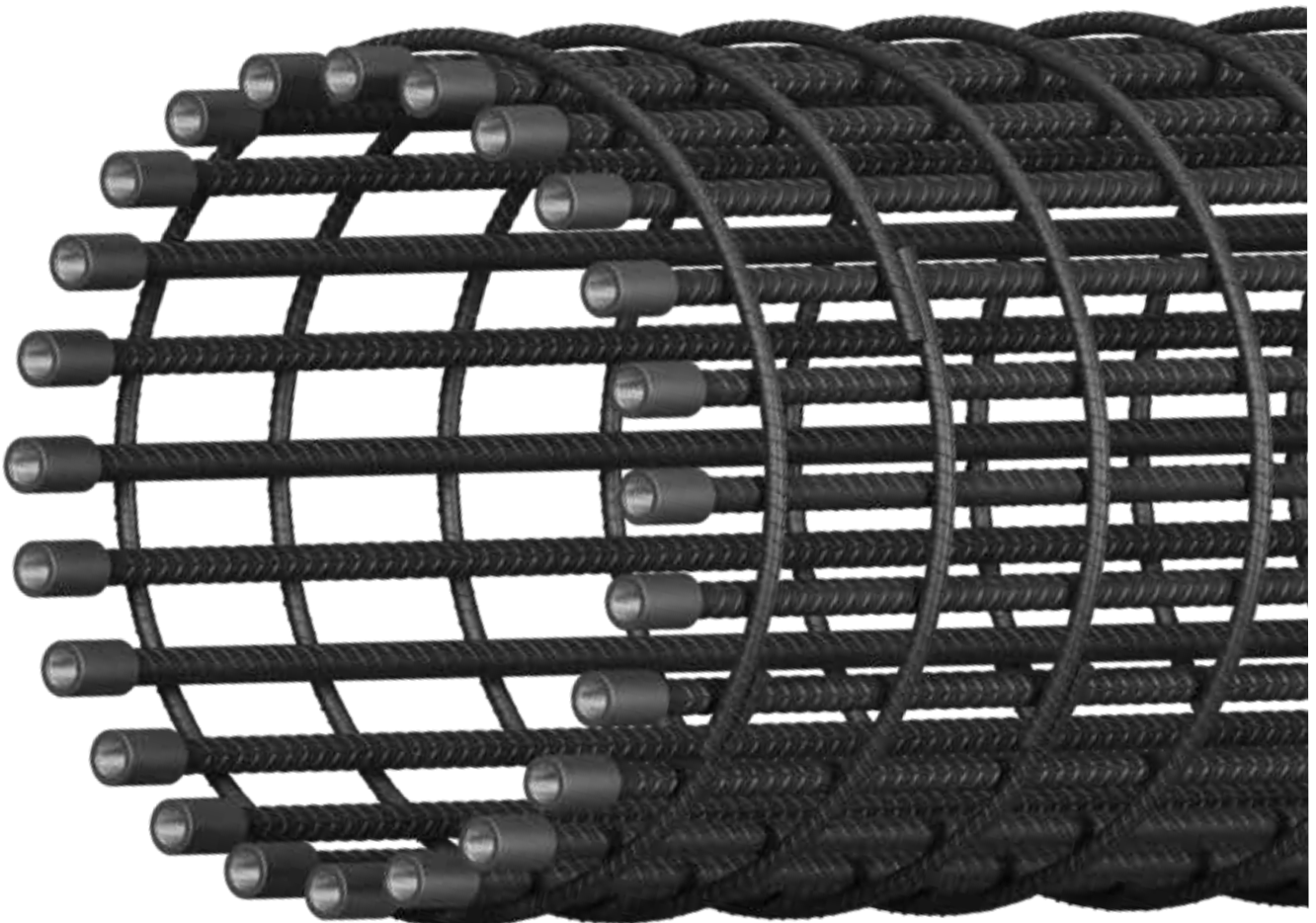

Technical approval TA1-F 5077 for Moment JT Couplers



Simplify design and construction



Reduce amount of reinforcement required



Reduce carbon footprint



Dedicated sales support

Moment JT Couplers produce a full strength joint yet they are among the smallest in the Moment range, best suited to large scale projects requiring a high volume of couplers.



The end of each bar to be joined is cut square and enlarged by cold forging. This increases the core diameter of the bar to ensure that the joint is stronger than the bar.

Parallel metric threads are cut onto the enlarged ends. A nominal allowance of +50mm per threaded bar end should be made for cutting square and cold forging. The threaded ends of the bars are protected by an external plastic sheath.

Couplers, which are usually supplied attached to the bar, have their internal threads protected by an internal plastic end cap. For certain applications, especially where Moment JT Couplers is being used in deep pours, the coupler end caps may not prevent the ingress of concrete fines. For these applications, further protection may be required.

Moment JT Couplers are also available to join bars of different diameters. For further information please refer to page 5 on Moment Reducer Couplers.

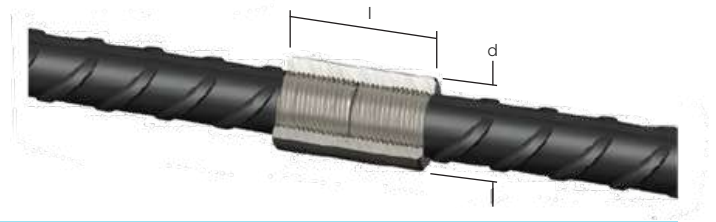

Dimensions

Bar Diameter ¹ (mm)	12/13	16	18 ³	19/20	22 ⁴	24/25	28/29	32	36	40
External Dia. (mm) d	24	28	28	32	32	40	45	50	57	62
Coupler length (mm) 2t	35	40	40	48	48	60	66	70	84	90
'Half Thread' Length (mm) t	17.5	20	20	24	24	30	33	36	42	45
Locknut Length (mm) l _n	12	12	12	12	12	15	15	15	20	20
Thread Size (mm)	M16	M20	M20	M24	M24	M30	M33	M36	M42	M45
Thread Pitch (mm)	2.0	2.5	2.5	3.0	3.0	3.5	3.5	4.0	4.5	4.5
Marking on Coupler ²	JT12	JT16	JT18	JT20	JT22	JT25	JT28	JT32	JT36	JT40

- 1 Bar Diameters shown in this table include sizes that are only available in specific markets or specific to grade ASTM A615 reinforcing bar. For ASTM A615 grade reinforcing bar, the Moment JRT system is generally recommended. Refer to page 9 for further information on Moment JRT.
- 2 Bar Diameters with small variance in size share the same coupler, however the couplers are only marked with the more commonly available size.
- 3 Bar Diameter 18 uses the same coupler dimensions as the JT16, only the marking on the coupler differs, however the plastic cap will contain the JT16 marking. In cases of short supply of JT18 couplers, JT16 may be used.
- 4 Bar Diameter 22 uses the same coupler dimensions as the JT20, only the marking on the coupler differs, however the plastic cap will contain the JT20 marking. In cases of short supply of JT22 couplers, JT20 may be used.
- 5 Bar diameter 50 is available upon request.

Moment JT Coupler - Type A

The Type A system utilises internally threaded couplers with a single right hand thread and is suitable for applications where the continuation bar can be rotated. The ends of the bars are upset and threaded for half the length of the coupler ('Half Thread').

Moment JT Coupler - Type B

The Type B uses the same coupler as the Type A system, but one bar is threaded for a full coupler length ('Full Thread'). It is used for applications where it is difficult but not impossible to rotate the continuation bar.

Moment JT Coupler - Type C

The Type C system has an additional locknut and is used where the continuation bar cannot be rotated. The continuation bar is threaded for the full coupler length plus the length of the locknut ('Extended Thread').



Installation

Moment JT Coupler - Type A

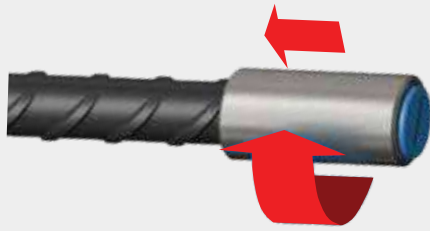

- 1 Screw the coupler to the rear of the thread on the fixed bar and lock tight. The bar end should be central within the coupler.



- 2 Remove the plastic cap from the coupler. Position and rotate the continuation bar in the coupler.



- 3 Tighten the joint using a wrench on the continuation bar. After tightening there should be no more than 4mm of exposed thread; for size 20mm and below, or 6mm for sizes 25mm and above.

Moment JT Coupler - Type B

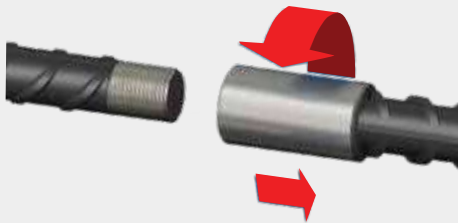

- 1 Screw the coupler to the rear of the thread on the continuation bar.



- 2 Position the continuation bar with the coupler against the end of the first bar.



- 3 Rotate the coupler from the continuation bar to engage against the rear of the thread on the opposing bar and lock tight.

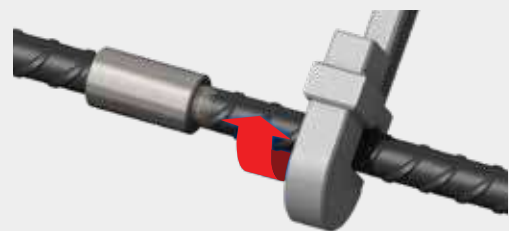

- 4 Using a wrench, rotate the continuation bar to lock the two bar ends against each other within the coupler. After tightening, the length of exposed thread should be no more than half of the coupler length plus 4mm for sizes 20mm and below, or 6mm for sizes 25mm and above.

Important Note: The additional thread lengths beyond the final coupler location on Type B and C connections are non-structural and are to be used for positioning purposes only.

 To ensure structural integrity of the connection, any actions, such as on-site bending, which induce cold working of the bar in the threaded region are to be strictly avoided.

Moment JT Coupler - Type C

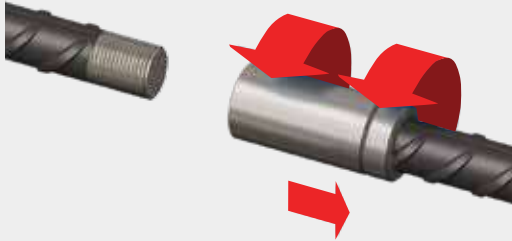

- 1 Screw the locknut followed by the coupler to the rear of the thread on the continuation bar.



- 2 Position the continuation bar with the coupler against the end of the first bar.



- 3 Rotate the coupler from the continuation bar to engage against the rear of the thread on the opposing bar and lock tight.

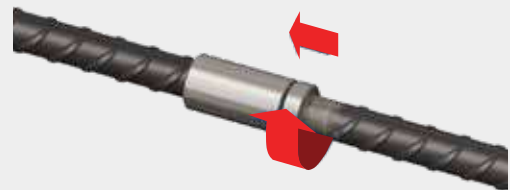

- 4 Rotate the locknut along the continuation bar to abut the coupler.

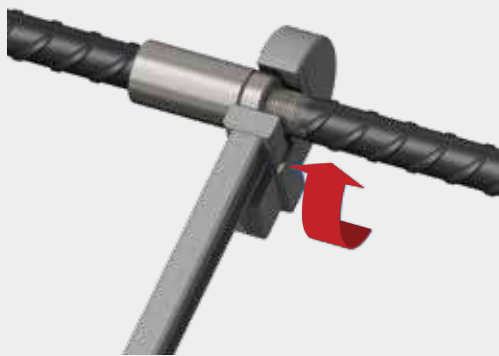

- 5 Hold the rebar in its required orientation and with a wrench tighten the locknut against the coupler. After tightening, the length of the exposed thread should be no more than half of the coupler length plus 4mm for sizes 20mm and below, or 6mm for sizes 25mm and above.

Important Note: The additional thread lengths beyond the final coupler location on Type B and C connections are non-structural and are to be used for positioning purposes only.



To ensure structural integrity of the connection, any actions, such as on-site bending, which induce cold working of the bar in the threaded region are to be strictly avoided.

Moment JT Reducer Couplers

Moment JT Reducer Couplers are designed to connect reinforcing bars of different diameters whilst still maintaining the full tensile strength of both reinforcing bars, ensuring the failure mode is ductile failure of the smaller bar.

For Type A reducer connections, both bars utilise standard Type A JT threads with a special coupler to connect the two bars.

Reducer connections requiring types B or C systems use the standard JT thread for the smaller bar and a modified JT thread for the larger bar which uses a thread pitch matching the smaller thread to allow simultaneous rotation of the coupler on both bars.

The locknut for a Type C reducer connection uses the standard locknut for the smaller bar.

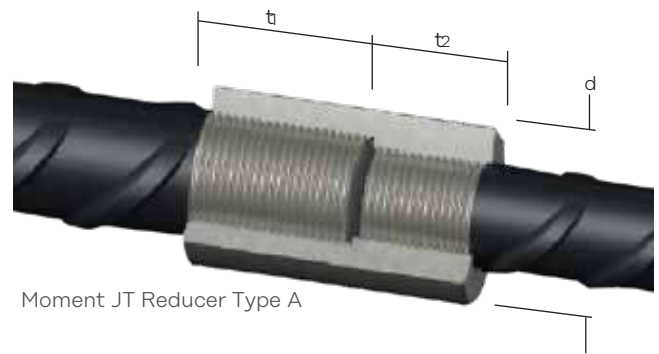

Moment JT Reducer Type A

Bar Diameter (mm)	20/16	25/16	25/20	28/20	28/25	32/20	32/25	32/28	36/32	40/25	40/28	40/32	40/36
External Dia. (mm) d	32	40	40	45	45	50	50	50	55	60	60	60	60
Larger Type A Thread Length (mm), t_1	24	30	30	33	33	36	36	36	42	45	45	45	45
Smaller Type A Thread Length (mm), t_2	20	20	24	24	30	24	30	33	36	30	33	36	42
Coupler Length (mm), $t_1 + t_2$	44	50	54	57	63	60	66	69	78	75	78	81	87
Locknut Length (mm), l_{n2}	12	12	12	12	15	12	15	15	15	15	15	15	20
Thread Form 1	M24	M30	M30	M33	M33	M36	M36	M36	M42	M45	M45	M45	M45
Thread Form 2	M20	M20	M24	M24	M30	M24	M30	M33	M36	M30	M33	M36	M42
Type A Thread Pitch 1 (mm)	3.0	3.5	3.5	3.5	3.5	4.0	4.0	4.0	4.5	4.5	4.5	4.5	4.5
Type A Thread Pitch 2 (mm)	2.5	2.5	3.0	3.0	3.5	3.0	3.5	3.5	4.0	3.5	3.5	4.0	4.5
Type B & C Thread Pitch (mm)	2.5	2.5	3.0	3.0	3.5	3.0	3.5	3.5	4.0	3.5	3.5	4.0	4.5

Notes: Other sizes are available on request. All transition couplers are made to order. Lead times and minimum order quantities may apply. Contact us for more details.

Moment JT Reducer Coupler - Type A

The Type A reducer connection utilises the same Type A JT threads ('Half thread') as the standard system with a special internally threaded coupler to connect the two different sized cold-forged and threaded bar ends together.

Type A connections are used where the continuation bar can be rotated.

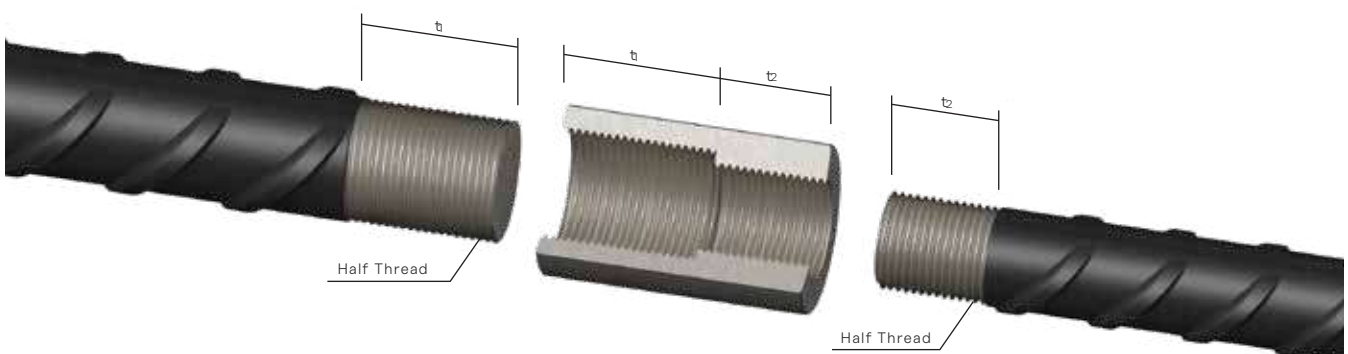

Moment JT Reducer Coupler - Type B

The Type B connection utilises a longer thread on the smaller bar equal to the length of the Coupler ('Reducer Full Thread'). The thread on the larger bar and the coupler is modified with a pitch matching the smaller thread ('Reducer Half Thread').

The coupler needs to be rotated from the smaller diameter rebar onto the larger. Type B connections are used where the continuation bar can be rotated for no more than one revolution.

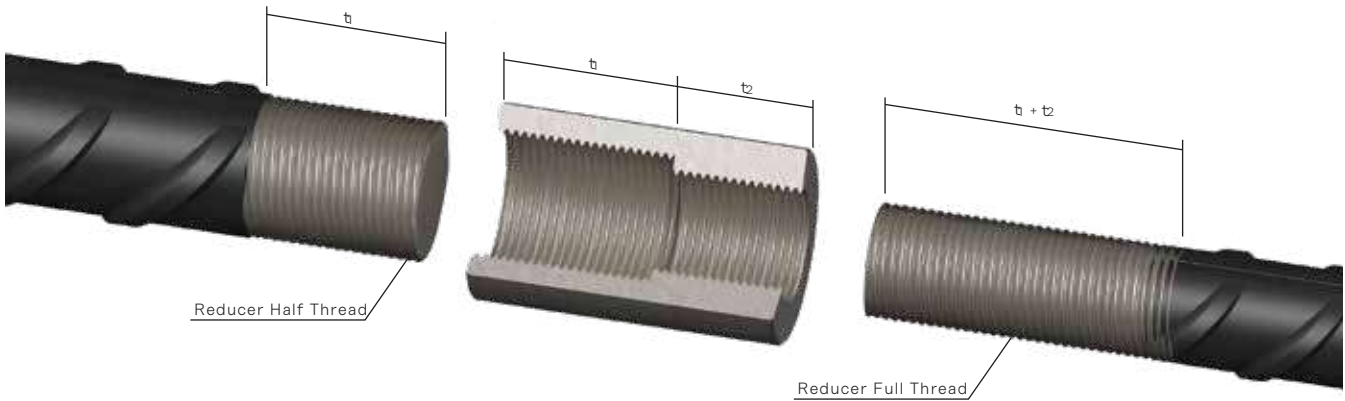

Moment JT Reducer Coupler - Type C

The Type C connection utilises the same coupler and thread pitches as for the Type B, together with a locknut and longer thread on the smaller bar ('Reducer Extended Thread').

The coupler needs to be rotated from the smaller diameter rebar onto the larger. Type C connections are used where the continuation bar cannot be rotated.

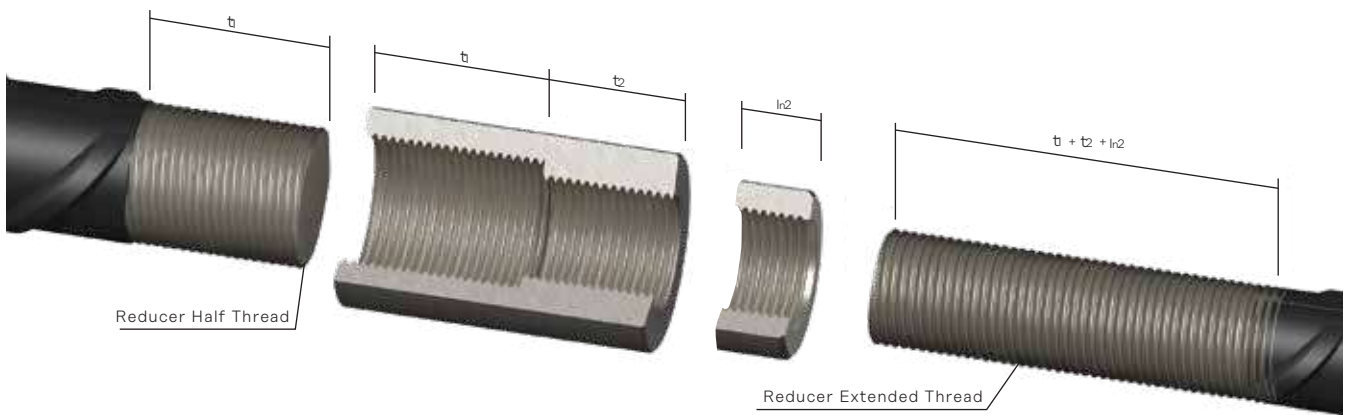

Important Note: The additional thread lengths beyond the final coupler location on Type B and Type C connections are non-structural and are to be used for positioning purposes only.

*Moment JT Reducer Couplers are made to order to project specific requirements. Lead times and minimum order quantities may apply. Contact us for further information.

Moment JT Terminator

The Moment JT Terminator provides an effective and proven method of achieving rebar end anchorage within concrete.

Anchorage of reinforcement within a concrete section is traditionally achieved by means of creating a long hooked end to the bar. These hooks can lead to problems when positioning the bar and can increase congestion. This can ultimately result in larger than necessary concrete sections at the location of hooked ends.

The Moment JT Terminator is essentially an oversized coupler capable of carrying the full tension load of the bar when it bears against the concrete in which it is cast. The Terminator removes the need for the hooked rebar end and can subsequently reduce congestion, simplifying bar placement. This in turn increases the speed of construction and gives greater flexibility in design. Typical applications include pile caps and beam-to-column connections.

To attach the Moment JT Terminator to the rebar, it is first necessary to enlarge the bar end and then form the thread on the enlarged bar end using a thread cutting machine. As with the Moment JT Coupler connection, the thread is such that the cross-sectional area of the bar end is not reduced, thus ensuring the tensile strength of the connection matches or exceeds that of the parent bar.

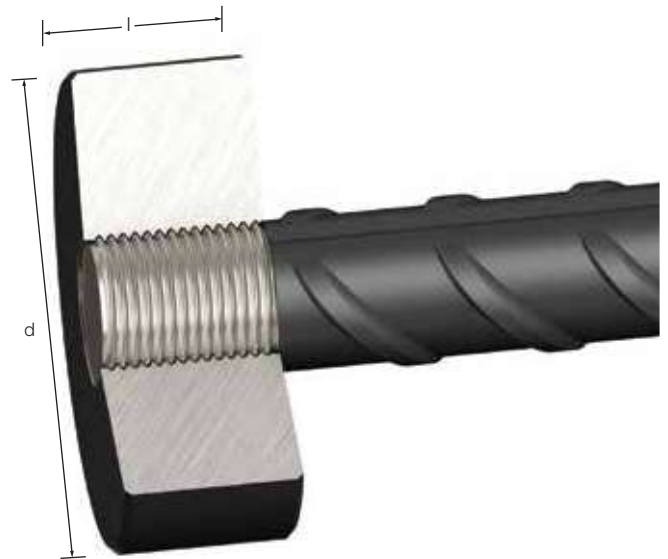

Bar Diameter (mm)	12/13	16	20	25	28	32	36	40
External Dia. (mm), d	24	36	40	56	60	65	75	80
Anchor Thickness (mm),	18	20	24	30	33	36	42	45
Thread Size (mm)	M16	M20	M24	M30	M33	M36	M42	M45
Thread Pitch (mm)	2.0	2.5	3.0	3.5	3.5	4.0	4.5	4.5

Notes: Moment JT Terminators with larger External Diameter's are available upon request. Contact us for more details.

Concrete Strength

When the above Sizes of Moment JT Terminators are used, the compressive strength of the concrete shall not be less than strength grade C32/40 (cylinder/cube). Where a lower concrete stress is required, Moment JT Terminators can be supplied to a larger diameter to suit the specific application.

Moment JT Weldable Couplers

Moment JT Weldable Couplers provide a convenient means of connecting reinforcing bars to structural steel plates or sections. One end is internally threaded with the JT thread form; the other end is prepared for welding to the steel.

The Moment JT Weldable Couplers are manufactured from Steel Grade S45C to JIS G 4051. The coupler is suitable for welding to structural steels EN BS 10025, Grade S275 (43A) or Grade S355 (Grade 50B), however the load conditions at the connection must be determined by the designer responsible for the structural element, along with the type and size of weld required.

Other important considerations include the type of electrode to be used, which must be matched to the properties of the plate and tube, and to the site conditions under which the welding will be undertaken. Welders should be qualified for the type of weld required.

Carbon Equivalent Value - The Carbon Equivalent value of these couplers may typically vary between 0.50-0.75, where the carbon equivalent value is given by $CEV = C + (Mn)/6 + (Ni + Cu)/15 + (Cr + Mo + V)/5$

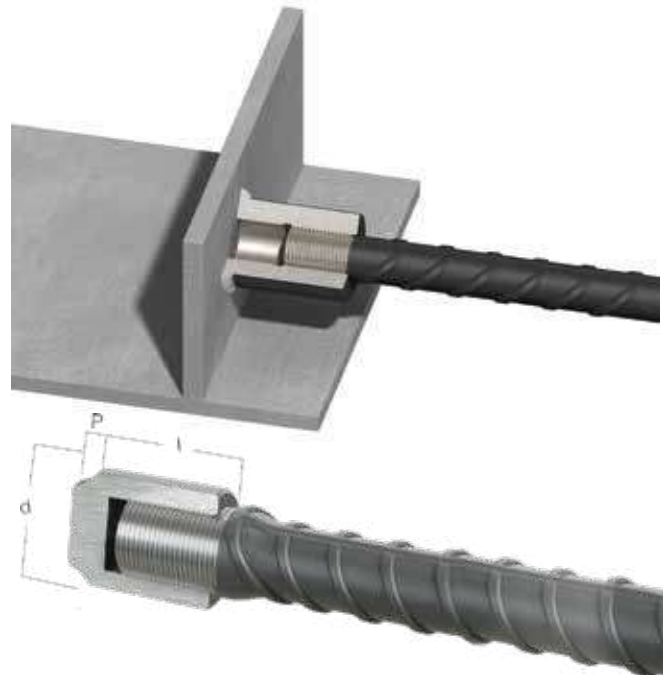

Bar Diameter (mm)	12/13	16	20	25	28	32	36	40	50
Coupler Diameter (mm), d	28	32	36	45	50	55	65	70	85
Coupler Length (mm), l	36	40	45	50	55	60	65	70	90
Thread Size (mm)	M16	M20	M24	M30	M33	M36	M42	M45	M53
Thread Pitch (mm)	2.0	2.5	3.0	3.5	3.5	4.0	4.5	4.5	4.0
Weld Preparation (mm), p	8	8	9	10	10	12	12	14	15

Installation



1 The coupler must first be welded to the steelwork.



2 When ready to extend, position the continuation bar into the sleeve.

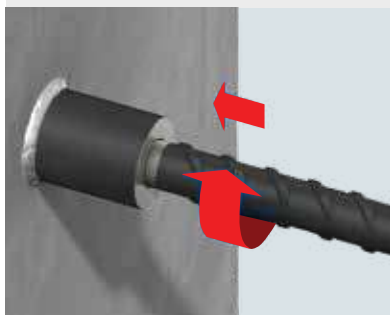

3 Rotate the bar into the coupler until tight.

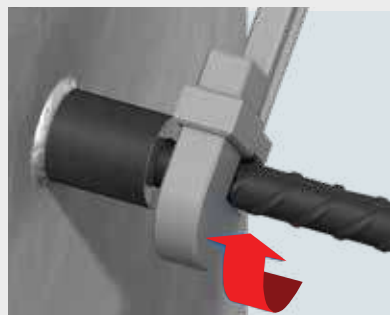

4 Tighten the continuation bar using a wrench.

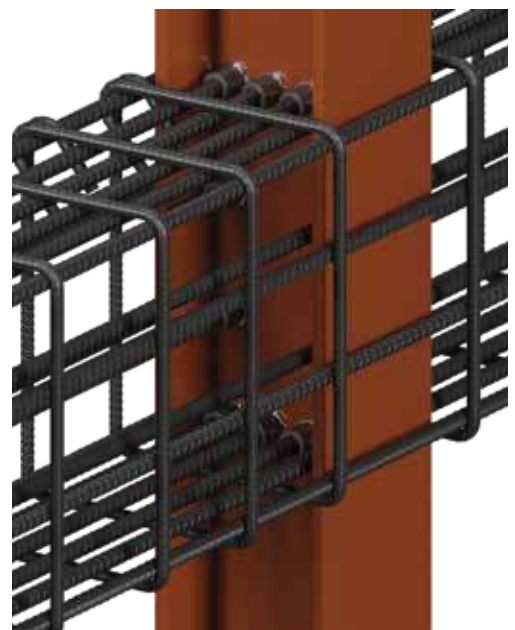

Moment JRT Couplers

The JRT system uses the same coupler sleeve as the standard JT system however the thread on the reinforcing bar is formed by rolling, best suited for high fatigue applications or when reduced cold-forging of the bar end is required.

The end of each bar to be joined is cut square and enlarged by cold forging to the pre-roll diameter for the thread size. This process allows for a thread size larger than bar diameter to be formed onto the bar, ensuring that the joint is stronger than the bar, whilst minimizing the amount of cold-forging that is required.

A nominal allowance of +50mm per threaded bar end should be made for cutting square and cold forging.

The reduced amount of cold-forging when compared to the standard JT cut thread also provides an advantage in markets where the reinforcing bar may not be as consistently compatible with the standard JT system. This is seen in some markets in Asia which have adopted the ASTM A615 grade reinforcing bar, whereby we recommend the JRT system.

The thread rolling process adopted in the JRT system produces a curved grain structure within the threaded end and also removes re-entrant corners typically seen in cut-thread profiles, leading to superior high cycle fatigue performance.

The JRT system is available in Types A, B & C, as shown for the JT system on page 2. For the type C system, the same lock-nut is used as for the standard JT system.

The JRT system is also compatible with the Moment JT Reducer, Terminator, and Weldable Couplers shown on pages 5 to 8.



Moment JTH Couplers

The Moment JTH Coupler is designed as a high performance coupler; suitable for connecting high strength reinforcing bars.

The JTH system adopts the same dimensions as the standard JT system however higher performance material is used in the coupler sleeve to achieve the higher capacities.

Designed to resist an equivalent bar stress up to 900MPa, the Moment JTH Coupler can provide bar break performance for the majority of grade B600 and Grade 75 reinforcing bars currently available in the market.

The threaded ends of the reinforcing bar is conducted in a similar process as the JT system, whereby the bar end is cut square and enlarged before a parallel metric thread is cut.

The Moment JTH Coupler can also be used with reinforcing bars that have been threaded with the Moment JRT thread.

The JTH system is available in Types A, B & C, as shown for the JT system on page 2. For the type C system, the same lock-nut is used as for the standard JT system.

The Moment JTH Reducer, Terminators, and Weldable Couplers can be made available upon request.



Bar Diameter (mm) ¹	12/13	16	18 ³	19/20	22 ⁴	24/25	28/29	32	36	40
External Dia. (mm) d	24	28	28	32	32	40	45	50	57	62
Coupler length (mm) 2t	35	40	40	48	48	60	66	72	84	90
'Half Thread' Length (mm) t	17.5	20	20	24	24	30	33	36	42	45
Locknut Length (mm) l _n	12	12	12	12	12	15	15	15	20	20
Thread Size (mm)	M16	M20	M20	M24	M24	M30	M33	M36	M42	M45
Thread Pitch (mm)	2.0	2.5	2.5	3.0	3.0	3.5	3.5	4.0	4.5	4.5
Marking on Coupler ²	JTH12	JTH16	JTH18	JTH20	JTH22	JTH25	JTH28	JTH32	JTH36	JTH40

¹ Bar Diameters shown in this table include sizes that are only available in specific markets or specific to grade ASTM A615 reinforcing bar. For ASTM A615 grade reinforcing bar, the JRT system is generally recommended. Refer to page 9 for further information on JRT.

² Bar Diameters with small variance in size share the same coupler, however the couplers are only marked with the more commonly available size.

³ Bar Diameter 18 uses the same coupler dimensions as the JT16, only the marking on the coupler differs, however the plastic cap will contain the JT16 marking. In cases of short supply of JT18 couplers, JT16 may be used.

⁴ Bar Diameter 22 uses the same coupler dimensions as the JT20, only the marking on the coupler differs, however the plastic cap will contain the JT20 marking. In cases of short supply of JT22 couplers, JT20 may be used.

Other Leviat Products

Ancon MBT Coupler

The Ancon MBT Coupler range provides a cost-effective method of joining reinforcing bars, particularly when the fixed bar is already in place and there is insufficient space for a hydraulic swaging press. They are easy to install and achieve failure loads higher than 108% of the characteristic yield strength of grade 500 reinforcing bar. Neither bar end preparation to form threads, nor bar rotation is required. MBT Couplers can also be used to join imperial or metric plain round or deformed reinforcing bars, making it ideal for alteration or refurbishment projects.



Moment Grout Coupler

Specifically made for precast concrete connections, the Moment Half Grout Coupler system combines the benefits of the JT threaded system, with the flexibility and tolerance of a grout system.

When used together with Moment's proprietary 100MPa grout, the coupler system is a bar break technology and is capable of carrying very high bar loads. On one end the coupler receives threaded rebar, whereas the opposite end provides the flexibility of a grout system. Consist of a one-piece design, the coupler is capable of carrying very high loads.



Moment Loop Box

The Moment Loop Box is available in 3 versions, Single, Double and Multi version including single, double and multi wire rope loops respectively to ensure strength in the connection.

The Moment Loop Box will need to fix to the formwork and the flexible folded wires will need to be pulled out to make a connection when ready on site. The load will be transferred from one concrete panel to the other panel via wire rope loop. High strength (1770 MPa) galvanized steel wire rope with 6 mm ϕ will need to be crimped by using compression sleeves / ferrule to form a loop at one end & to transfer a load axially through other ends. The load is transferred from one concrete panel to the other panel via wire rope loop.



Contact Leviat locally

For more information on the products featured here, please contact Leviat:

Malaysia

Leviat

28 Jalan Anggerik Mokara 31/59
Kota Kemuning, 40460 Shah Alam
Selangor
Tel: +603 - 5122 4182
Email: info.my@leviat.com

Singapore

Leviat

10 Benoi Sector
Singapore 629845
Tel: +65 - 6266 6802
Email: info.sg@leviat.com

India

Leviat

Unit S4, 902, A Wing
Lodha iThink Campus Building
Panchpakhandi, Pokharan Road 2
Thane 400608
Tel: +91 - 22 6953 3700
Email: info.in@leviat.com

Philippines

Leviat

27F Office A, Podium West Tower
12 ADB Avenue, Ortigas Center,
Mandaluyong City,
1550 Philippines
Tel: +632 - 7957 6381
Email: info.ph@leviat.com

Contact our trusted distributors

We closely collaborate with our distributors to meet all your needs across Asia.

Indonesia

PT Beton Perkasa Wijaksana
Jl. Penjernihan No. 40 Jakarta 10210
Tel: +62 21 571 2644
Email: bpw@betonperkasa.com

Thailand

Cons Inno Co., Ltd
88 Moo 4 Bangsithong Bangkruay
Nonthaburi 11130
Tel: +66 92 786 6464
Email: info@consinno.com

Vietnam

NDS Engineering and Trading JSC
793/49/1 Tran Xuan Soan Street
Tan Hung Ward, Dist 7
Ho Chi Minh City
Tel: +84 28 3 620 0659
Email: info@ndsec.vn

Sri Lanka

Amtek Engineering (Pvt) Ltd
No. 28, Sulaiman Terrace, Colombo 05
Sri Lanka
Tel: +94 777 420 710
Email: info@amtek.lk

Bangladesh

GPH Ispat Ltd
Crown Chamber - 325 Asadgonj
Chittagong-4000, Bangladesh
Tel: +880 31 638 507
Email: info@gphispac.com.bd

Contact Leviat worldwide

For more information on the products featured here, please contact leviat:

Australia

98 Kurrajong Avenue,
Mount Druitt, Sydney, NSW 2770
Tel: +61 - 2 8808 3100
Email: info.au@leviat.com

Austria

Leonard-Bernstein-Str. 10
Saturn Tower, 1220 Wien
Tel: +43 - 1 - 259 6770
Email: info.at@leviat.com

Belgium

Industrielaan 2
1740 Ternat
Tel: +32 - 2 - 582 29 45
Email: info.be@leviat.com

China

Room 601 Tower D,
Vantone Centre
No. A6 Chao Yang Men Wai Street
Chaoyang District
Beijing P.R. China 100020
Tel: +86 - 10 5907 3200
Email: info.cn@leviat.com

Czech Republic

Business Center Šafránková
Šafránková 1238/1
155 00 Praha 5
Tel: +420 - 311 - 690 060
Email: info.cz@leviat.com

Finland

Vädursgatan 5
412 50 Göteborg / Sweden
Tel: +358 (0)10 6338781
Email: info.fi@leviat.com

France

6, Rue de Cabanis
FR 31240 L'Union
Toulouse
Tel: +33 - 5 - 34 25 54 82
Email: info.fr@leviat.com

Germany

Liebigstrasse 14
40764 Langenfeld
Tel: +49 - 2173 - 970 - 0
Email: info.de@leviat.com

India

Unit S4, 902, A Wing
Lodha iThink Campus Building
Panchpakhandi, Pokharan Road 2
Thane 400608
Tel: +91 - 22 6953 3700
Email: info.in@leviat.com

Italy

Via F.lli Bronzetti 28
24124 Bergamo
Tel: +39 - 035 - 0760711
Email: info.it@leviat.com

Malaysia

28 Jalan Anggerik Mokara 31/59
Kota Kemuning, 40460 Shah Alam
Selangor
Tel: +603 - 5122 4182
Email: info.my@leviat.com

Netherlands

Oostermaat 3
7623 CS Borne
Tel: +31 - 74 - 267 14 49
Email: info.nl@leviat.com

New Zealand

2/19 Nuttall Drive, Hillsborough,
Christchurch 8022
Tel: +64 - 3 376 5205
Email: info.nz@leviat.com

Norway

Vestre Svanholmen 5
4313 Sandnes
Tel: +47 - 51 82 34 00
Email: info.no@leviat.com

Philippines

27F Office A, Podium West Tower
12 ADB Avenue, Ortigas Center,
Mandaluyong City,
1550 Philippines
Tel: +632 - 7957 6381
Email: info.ph@leviat.com

Poland

Ul. Obornicka 287
60-691 Poznań
Tel: +48 - 61 - 622 14 14
Email: info.pl@leviat.com

Singapore

10 Benoi Sector
Singapore 629845
Tel: +65 - 6266 6802
Email: info.sg@leviat.com

Spain

Polígono Industrial Santa Ana
c/ Ignacio Zuloaga, 20
28522 Rivas-Vaciamadrid
Tel: +34 - 91 632 18 40
Email: info.es@leviat.com

Sweden

Vädursgatan 5
412 50 Göteborg
Tel: +46 - 31 - 98 58 00
Email: info.se@leviat.com

Switzerland

Grenzstrasse 24
3250 Lyss
Tel: +41 (0) 800 22 66 00
Email: info.ch@leviat.com

United Arab Emirates

RA08 TB02, PO Box 17225
JAFZA, Jebel Ali, Dubai
Tel: +971 (0)4 883 4346
Email: info.ae@leviat.com

United Kingdom

President Way,
President Park,
Sheffield S4 7UR
Tel: +44 - 114 275 5224
Email: info.uk@leviat.com

USA / Canada

6467 S Falkenburg Road
Riverview, FL 33578
Tel: (800) 423-9140
Email: info.us@leviat.us

For countries not listed

Email: info@leviat.com

Notes regarding this document

© Protected by copyright. The information in this publication is based on state-of-the-art technology at the time of publication. In every case, project working details should be entrusted to appropriately qualified and experienced persons. Leviat shall not accept liability for the accuracy of the information in this document or for any printing errors. We reserve the right to make technical and design changes at any time. With a policy of continuous product development, Leviat reserves the right to modify product design and specification at any time.

